

HELICOIDAL PEYRARD–BISHOP MODEL OF DNA DYNAMICS

SLOBODAN ZDRAVKOVIĆ

To cite this article: SLOBODAN ZDRAVKOVIĆ (2011) HELICOIDAL PEYRARD–BISHOP MODEL OF DNA DYNAMICS, Journal of Nonlinear Mathematical Physics, 18:sup2, 463-484, DOI: [10.1142/S1402925111001635](https://doi.org/10.1142/S1402925111001635)

To link to this article: <https://doi.org/10.1142/S1402925111001635>



Published online: 04 Mar 2013.



Submit your article to this journal [↗](#)



Article views: 192



View related articles [↗](#)



Citing articles: 13 View citing articles [↗](#)

HELICOIDAL PEYRARD–BISHOP MODEL OF DNA DYNAMICS*

SLOBODAN ZDRAVKOVIĆ

*Institut za Nuklearnu Nauku Vinča, Univerzitet u Beogradu
Poštanski fah 522, 11001 Beograd, Serbia
szdjidji@vinca.rs*

Received 31 October 2010

Revised 30 January 2011

Accepted 2 February 2011

A nonlinear model describing DNA dynamics, called helicoidal Peyrard–Bishop model, is described. It is shown that the model can explain a local opening of a DNA helix during transcription. An impact of friction forces is also studied. It is pointed out that a role of viscosity is crucial for DNA-RNA transcription.

Keywords: Helicoidal Peyrard–Bishop model; solitons; DNA-RNA transcription; nonlinear Schrödinger equation; localised modulated wave; local opening of DNA; viscosity.

0. Introduction

DNA is doubtlessly the most sophisticated molecule in Nature. It exists in a very centre of secrets that should be unveiled to understand life. However, whenever a scientist moves towards the centre of the secret he feels that the secret's radius becomes bigger and bigger and the centre mysteriously eludes. A helicoidal structure of DNA is fascinating. It looks like an enfolded molecule, being able to wrap its mysteriousness.

This review paper represents the author's admiration of this beauty and his attempts to penetrate into the Nature's wander called DNA. In Sec. 1 some information about the molecule is offered for people who are not biologists. Section 2 represents a brief mathematical introduction important for the rest of the paper. One of nonlinear models describing DNA dynamics is explained in Sec. 3, as well as its improvement when viscosity is taken into consideration. The paper is closed with some concluding remarks in Sec. 5.

A special attention is devoted to mathematical basis of the model. A nonlinear differential equation is solved using a semi-discrete approximation, which means that an envelope of the wave is treated in a continuum limit while a carrier component includes discreteness. This is an example of a multiple-scale method (derivative-expansion method), a procedure well-known in mathematical physics. Finally, a well-known nonlinear Schrödinger equation (NLSE) is obtained. It is shown in Sec. 3.4 that the NLSE does not have an analytical

*Work supported by Serbian Ministry of Sciences under the programs 142034G and III 45010.

solution when viscosity is taken into consideration as its nonlinear parameter becomes complex.

1. DNA Molecule

In this introductory section some basics of molecular biology of nucleic acids are explained. More information can be found in a variety of textbooks [1–4].

1.1. DNA structure

It is well known that DNA molecule is a double helix. This means that it consists of two complementary polymeric chains twisted around each other [2]. Its structure was determined in 1953. This was explained in a historic one page paper [5]. The DNA molecule is a biopolymer as each strand is a polymeric collection of nucleotides. Each nucleotide consists of a sugar, a phosphate group and a base. This is shown in Fig. 1. There are four different bases. These are: thymine (T) and cytosine (C) which are pyrimidines and adenine (A) and guanine (G) which are purines. The sugar of each nucleotide is linked by a phosphate group to a sugar of the adjacent nucleotide (Fig. 1). There are only two possible pairs and these are AT and CG. The two chains are joined together by hydrogen bonds, which will be explained later.

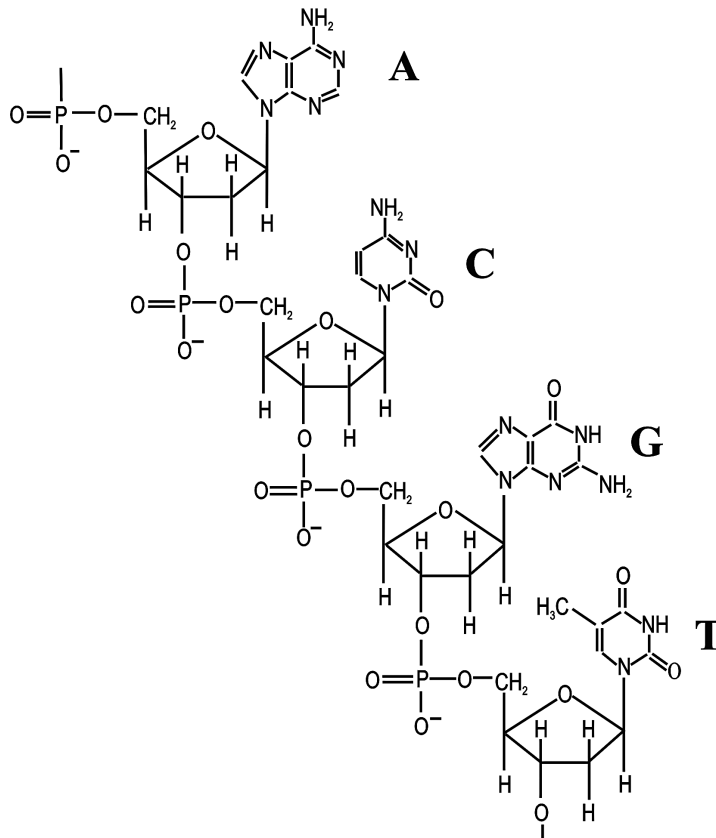

Fig. 1. DNA chain including four different nucleotides.

DNA is the biggest known molecule. Its relative molar mass can have a value of 10^9 . The molecule of such mass, extracted from E-coli, is about $400 \mu\text{m}$ long [3] while DNA in human cell can be as long as 2m. The molar masses of the bases, the phosphate and the sugar are:

$$M_T = 126 \text{ g/mol} \quad M_C = 111 \text{ g/mol} \quad M_P = 95 \text{ g/mol}$$

$$M_A = 135 \text{ g/mol} \quad M_G = 151 \text{ g/mol} \quad M_S = 134 \text{ g/mol}.$$

Notice that the masses of nucleotides differ from a mean value for up to about 4%. This is important as simplified models usually assume a homogeneous crystal structure meaning that all nucleotides are equal. Hence, for the average nucleotide mass a value $m = 5.1 \cdot 10^{-25} \text{ kg}$ will be used in this paper. Notice that, to obtain the nucleotide from its constituents, three water molecules should be removed. It might be important to notice that the masses of the AT and the CG pairs are equal. DNA density is about 1.7 g/cm^3 [3]. The diameter of the helix is about 20 \AA and each chain makes a complete turn every 34 \AA [2].

1.2. Chemical bonds in DNA

A chemical bond is a force that holds atoms together. Atoms united by strong covalent bonds belong to the same molecule. For example, in a system $\text{O-H} \cdots \text{O}$ the covalent bond is stronger and shorter (line) while the hydrogen bond is weaker and longer (dots). This means that the left oxygen atom and the hydrogen belong to the same water molecule and the right oxygen does not. Each water molecule can form four hydrogen bonds with the neighbouring molecules. The nucleotides are also connected by the covalent bonds. It was mentioned above that the two chains are joined together by the weak hydrogen bonds. The CG pair is shown in Fig. 2. One can notice three hydrogen bonds. It is important to keep in mind that A and T are attached by a double bond only.

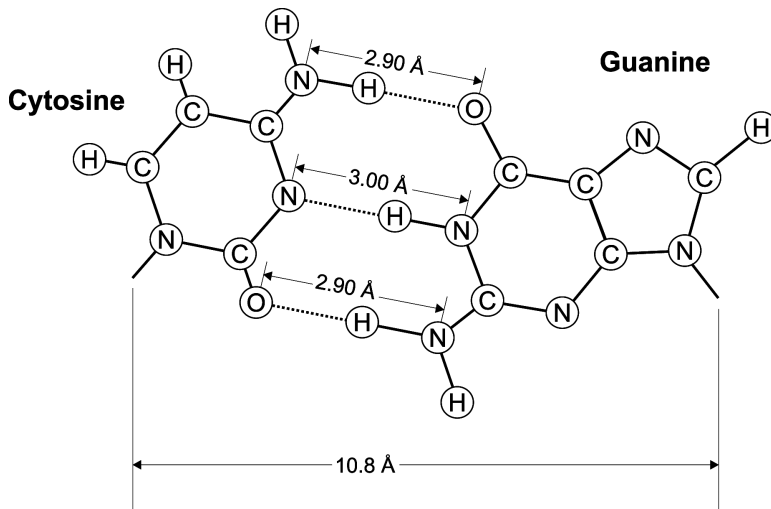

Fig. 2. The CG pair.

A number of covalent bonds an atom forms is called its valence. For example, oxygen can form two covalent bonds, the valence of nitrogen is three and of carbon is four. This can be easily recognized in Fig. 1.

We should know that the hydrogen bonds are only one type of the weak forces but crucial for DNA molecule. Let us compare the bonds mentioned above. Required energies to break C-C and C-N covalent bonds are 348.6kJ/mol and 336kJ/mol, respectively [3]. Energy of hydrogen bonds is 4–29kJ/mol [3]. Its mean value is about 16kJ/mol, which is eight times the average energy of thermal motion of molecules at room temperature [2].

1.3. DNA, RNA, gene

A gene is a DNA segment responsible for a biosynthesis of one polypeptide chain. When a protein contains more than one polypeptide chain, each chain is made separately. The average gene contains about 900 to 1500 nucleotide pairs [2]. As all the sugars and the phosphates are equal it is obvious that a genetic information is determined by a sequence of the base pairs.

Ribonucleic acid (RNA) is a bridge between DNA and proteins. Namely, DNA controls the biosynthesis of the proteins using RNA molecule. For this to be done the genetic information should be transferred from DNA to much shorter single stranded RNA. This process is called transcription.

To understand a complete structure of the double helix as well as DNA dynamics we should know how the nucleotides interact with water molecules. Bases are hydrophobic, which means that they are insoluble in water. On the other hand, the sugars and the phosphates form bonds to water molecules [2]. As a result we can imagine sugar-phosphate backbone to be on a surface of a cylinder while the bases are oriented toward its centre. This means that the sugar-phosphate backbone represents a protection for the genetically crucial bases.

2. Solitons

This short section represents a mathematical basis important for the rest of the paper. It is assumed that soliton and solitonic wave are synonyms. A definition of the soliton will be explained referring to [6].

Let $\Phi(x, t)$ be a solution of a certain partial differential equation (PDE). If the function Φ depends on x and t through a coordinate ξ defined as

$$\xi = x - ut \tag{2.1}$$

where u is constant then the PDE becomes an ordinary differential equation (ODE). If so then $\Phi(\xi)$ represents a travelling wave [6]. This is shown in Fig. 3.

A solitonic wave is defined as a localized travelling wave. An example is shown in Fig. 4(a). There is a more general definition of the soliton. The soliton is also a type of the travelling wave such that a transition from an asymptotic state $\xi \rightarrow -\infty$ into $\xi \rightarrow +\infty$ is localized in ξ [6]. Such soliton is shown in Fig. 4(b).

An example of the soliton shown in Fig. 4(a) can be a solution of the Korteweg-de Vries (KdV) equation which is

$$\Phi_t + \alpha\Phi\Phi_x + \Phi_{xxx} = 0 \tag{2.2}$$

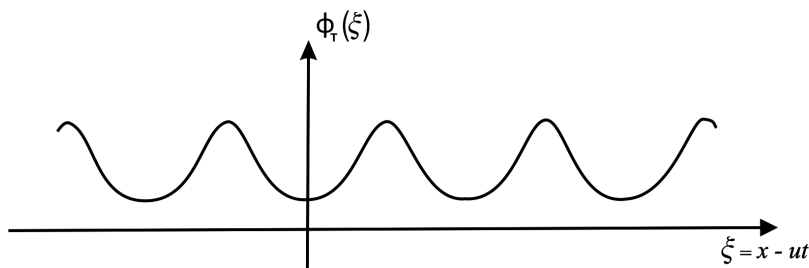

Fig. 3. A travelling wave.

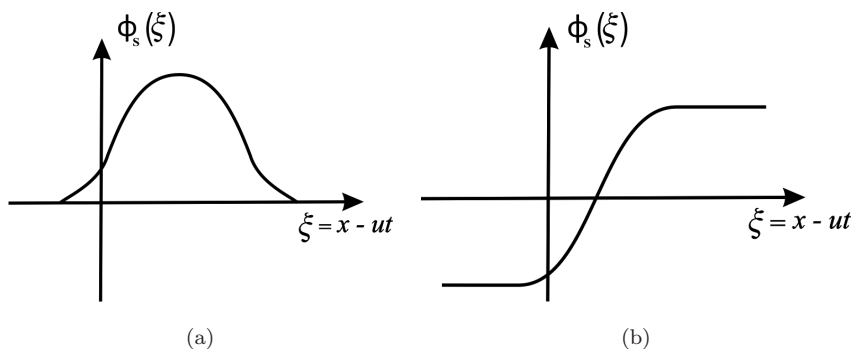

Fig. 4. Solitonic waves (a) An envelope solitonic wave or a bell type soliton. (b) A solitonic wave with different asymptotic values for $\xi \rightarrow -\infty$ and $\xi \rightarrow +\infty$.

where $\Phi \equiv \Phi(x, t)$, indexes t and x denote partial derivatives and α is a constant. The solution of (2.2) is so-called a bell type soliton

$$\Phi(x - ut) = \frac{3u}{\alpha} \operatorname{sech}^2 \left[\frac{\sqrt{u}}{2}(x - ut) \right]. \tag{2.3}$$

It is important to notice a general characteristic of the solitons which is a dependence of the amplitude from its velocity [7, 8]. The waves with higher velocities are both faster and shorter, which can be easily recognized from (2.3) if the solitonic width Λ is defined through its wave number as

$$\frac{2\pi}{\Lambda} = \frac{\sqrt{u}}{2}. \tag{2.4}$$

This was experimentally proven in the middle of the 19th century [9] and is demonstrated in Fig. 5.

An example of the soliton shown in Fig. 4(b) can be a solution of the sine-Gordon equation

$$\Phi_{xx} - \Phi_{tt} = \sin \Phi \tag{2.5}$$

where $\Phi \equiv \Phi(x, t)$ and indexes t and x denote partial derivatives as above. The solution of (2.5) is a kink soliton (+) or a kink antisoliton (-) [6]

$$\Phi = 4 \operatorname{arc} \operatorname{tg} \left[\exp \frac{\pm(x - ut)}{\sqrt{1 - u^2}} \right]. \tag{2.6}$$

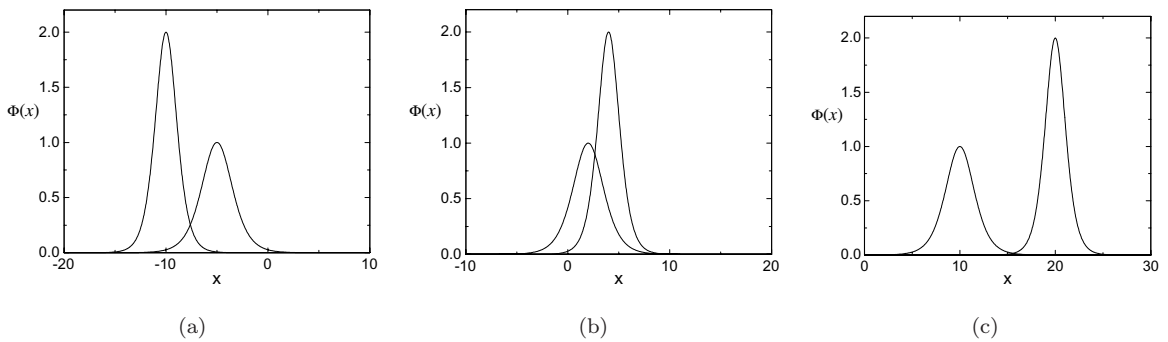

Fig. 5. The function (2.3) for $\alpha = 3$. The velocities are: $u = 2$ (faster soliton) and $u = 1$. (a) $t = -5$. (b) $t = 2$. (c) $t = 10$.

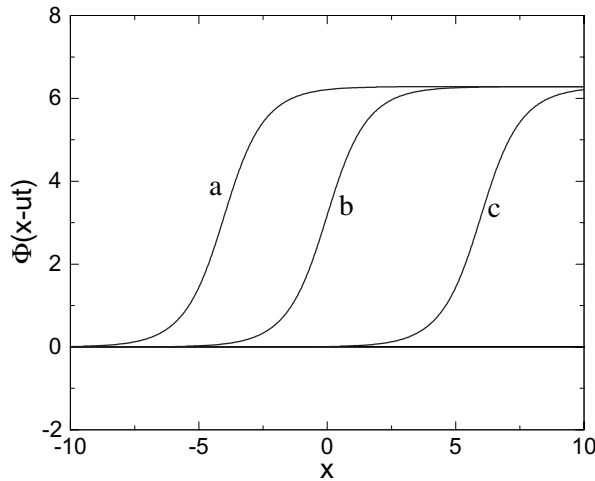

Fig. 6. The function (2.5) for $u = 0.2$. (a) $t = -20$. (b) $t = 0$. (c) $t = 30$.

The kink soliton is shown in Fig. 6. The corresponding antisoliton would be a decreasing function.

Both examples, the KdV and the sine-Gordon equations, have been used in nonlinear biophysics. The KdV equation does not have an application in the theory of DNA but can be used to describe dynamics of microtubule [10].

The sine-Gordon equation, i.e. the solitons shown in Figs. 4(b) and 6, are widely used in nonlinear DNA dynamics. Some of the models relying on this equation will be mentioned at the beginning of the next section.

This paper is primarily devoted to the helicoidal Peyrard–Bishop (HPB) model. According to this nonlinear model, DNA dynamics is described by a modulated solitonic wave, given by (3.32). When viscosity is taken into consideration the wave becomes demodulated and, consequently, looks like the envelope soliton shown in Fig. 4(a). Notice that the equation (3.32) becomes like (2.3) if cosines are set to be zero. This is an interesting point requiring further research.

3. Nonlinear Models of DNA

DNA is doubtlessly one of the most important and the most interesting biomolecules. There have been many attempts to describe its complex dynamics with appropriate models. Some of them, both linear and nonlinear, were described by Yakushevich [11].

It was in 1980 when Englander *et al.* suggested that nonlinear effects might play an important role in the DNA dynamics [12]. The authors stated that the nonlinear effects may focus the vibration energy of DNA into localized soliton-like excitations.

A key problem in each model is a choice of degrees of freedom. Simply speaking, one can talk of either torsional or vibrational dynamics [13], i.e. of torsional or vibrational models. Of course, some extensions, i.e. models combining rotational and transverse motions using both angular and radial coordinates, are possible [14, 15].

An example of the torsional models is Y model, introduced by Yakushevich [16]. The model has been studied, extended and improved [17–23]. According to this model, DNA dynamics is represented by the wave shown in Figs. 4(b) and 6.

Another interesting example is a model introduced by Daniel and Vasumathi [24–26]. This model is a certain mixture of the plane-base rotator (PBR) model and the Heisenberg’s spin model for a ferromagnetic chain. The PBR model was proposed by Yomosa [27, 28] and improved by Homma and Takeno [29]. According to this approach the degree of freedom characterizing base rotations in the plane perpendicular to the helical axis around the backbone structure is assumed while the introduced Hamiltonian is based on the Heisenberg’s spin model for the ferromagnetic chain. Like above, all this brings about the wave shown in Figs. 4(b) and 6. It may be interesting to point out that this approach can be used to study modulation instability in DNA double helix [30] as well as DNA-protein interaction [31].

In what follows, an example of the vibrational models will be explained in details. It will be shown that the wave describing DNA dynamics is a localized modulated wave. Its envelope is similar to the wave shown in Fig. 4(a).

3.1. The Peyrard–Bishop (PB) model

The B-form DNA in the Watson–Crick model is a double helix, which consists of two strands s_1 and s_2 as shown in Fig. 7. The nucleotides are linked by the nearest-neighbor harmonic interactions along the chains [32]. It was explained in Sec. 1.1 that the masses of nucleotides do not differ too much which means that one can assume a homogeneous crystal structure. Hence, a common mass m for all the nucleotides and the same coupling constant k for the harmonic longitudinal springs along each strand are assumed.

The strands are coupled to each other through the hydrogen bonds, which are supposed to be responsible for transversal displacements of the nucleotides. As these bonds are weak while the harmonic longitudinal are strong the PB model neglects all the displacements beside the transversal [32]. The hydrogen bond is modeled by the Morse potential

$$V_M(u_n - v_n) = D[e^{-a(u_n - v_n)} - 1]^2 \quad (3.1)$$

where u_n and v_n are the displacements of the nucleotides at the position n from their equilibrium positions along the direction of the hydrogen bond. Notice that u_n and v_n in

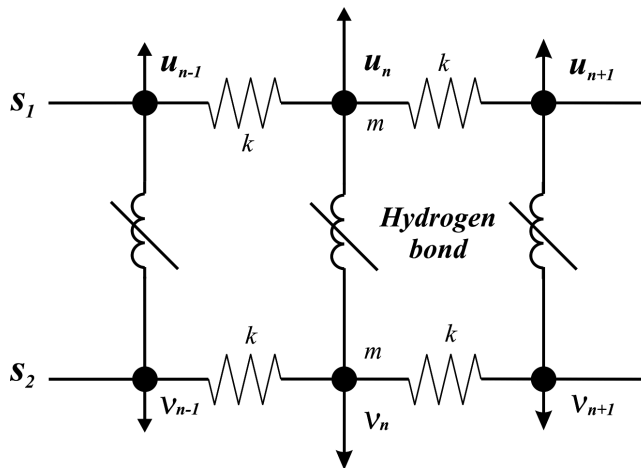

Fig. 7. A graphical representation of the simple model for DNA strands.

Fig. 7 have opposite signs. The parameters D and a in (3.1) are the depth and the inverse width of the Morse potential well, respectively. Therefore, the Hamiltonian for the DNA chain is

$$H = \sum \left\{ \frac{m}{2}(\dot{u}_n^2 + \dot{v}_n^2) + \frac{k}{2}[(u_n - u_{n-1})^2 + (v_n - v_{n-1})^2] \right\} + V_M(u_n - v_n) \quad (3.2)$$

where \dot{u}_n and \dot{v}_n represent the appropriate velocities. The Morse potential represents not only the hydrogen bonds but the repulsive interactions of the phosphate and the surrounding solvent action as well [33].

We are not going to proceed with the explanations concerning the PB model as all its ideas are included in the extended version which is a topic of the next section.

3.2. The helicoidal Peyrard–Bishop (HPB) model

The model explained above does not take helicoidal structure of DNA into consideration. The improved version of the PB model, introduced by Dauxois [33], does. It would be fair to call this model as the Peyrard–Bishop–Dauxois model. However, this name has been usually used for a somewhat similar model [34, 35]. This is why a name helicoidal Peyrard–Bishop (HPB) model might be a more appropriate choice.

To improve the PB model a new term, describing the helicoidal interactions, should be added to the Hamiltonian (3.2). Let us imagine that DNA in Fig. 7 is twisted. If so then a certain nucleotide, belonging to the strand s_1 , will come to the position s_2 after a turn of π . This means that a nucleotide at the site n of one strand interacts with both $(n + h)$ th and $(n - h)$ th nucleotides of the other strand [33]. It is assumed that this additional term is harmonic and the whole Hamiltonian, describing the HPB model, becomes [33]

$$H = \sum \left\{ \frac{m}{2}(\dot{u}_n^2 + \dot{v}_n^2) + \frac{k}{2}[(u_n - u_{n-1})^2 + (v_n - v_{n-1})^2] + \frac{K}{2}[(u_n - v_{n+h})^2 + (u_n - v_{n-h})^2] + D[e^{-a(u_n - v_n)} - 1]^2 \right\} \quad (3.3)$$

where K is the harmonic constant of the helicoidal spring. As the helix has a helical pitch of about 10 base pairs (bp) per turn [36] one can assume $h = 5$.

In what follows a whole mathematical procedure will be shown and it will be demonstrated that DNA dynamics can be explained by the modulated solitonic wave. Of course, some characteristics of the wave will be studied.

A first step is to introduce new coordinates representing the in-phase and the out-of-phase transversal motions as

$$x_n = (u_n + v_n)/\sqrt{2}, \quad y_n = (u_n - v_n)/\sqrt{2}. \tag{3.4}$$

This is convenient because the Hamiltonian (3.3) brings about the following completely decoupled dynamical equations of motion

$$m\ddot{x}_n = k(x_{n+1} + x_{n-1} - 2x_n) + K(x_{n+h} + x_{n-h} - 2x_n) \tag{3.5}$$

$$m\ddot{y}_n = k(y_{n+1} + y_{n-1} - 2y_n) - K(y_{n+h} + y_{n-h} + 2y_n) + 2\sqrt{2}aD(e^{-a\sqrt{2}y_n} - 1)e^{-a\sqrt{2}y_n}. \tag{3.6}$$

The first of them describes usual linear waves (phonons) while the second one describes nonlinear waves. It is important to notice that nonlinearity comes from the exponential terms, i.e. from the Morse potential. This means that the weak hydrogen bonds are responsible for the nonlinear effects in DNA and, maybe, in all biological systems. We restrict our attention on the second nonlinear equation and assume that the oscillations of nucleotides are large enough to be anharmonic but still small enough so that the nucleotides oscillate around the bottom of the Morse potential well. This suggests the transformation

$$y = \varepsilon\Phi; \quad (\varepsilon \ll 1). \tag{3.7}$$

A true meaning of the parameter ε will be seen later. Equations (3.6) and (3.7) bring about

$$\begin{aligned} \ddot{\Phi}_n = & \frac{k}{m}(\Phi_{n+1} + \Phi_{n-1} - 2\Phi_n) - \frac{K}{m}(\Phi_{n+h} + \Phi_{n-h} + 2\Phi_n) \\ & - \omega_g^2(\Phi_n + \varepsilon\alpha\Phi_n^2 + \varepsilon^2\beta\Phi_n^3) \end{aligned} \tag{3.8}$$

where

$$\omega_g^2 = \frac{4a^2D}{m}, \quad \alpha = \frac{-3a}{\sqrt{2}} \quad \text{and} \quad \beta = \frac{7a^2}{3}. \tag{3.9}$$

The nonlinear wave Eq. (3.8) can be solved using a semi-discrete approximation [37] according to which we look for wave solutions of the form

$$\Phi_n(t) = F_1(\xi)e^{i\theta_n} + \varepsilon[F_0(\xi) + F_2(\xi)e^{i2\theta_n}] + \text{cc} + O(\varepsilon^2) \tag{3.10}$$

$$\xi = (\varepsilon nl, \varepsilon t), \quad \theta_n = nql - \omega t \tag{3.11}$$

where l is the distance between two neighbouring nucleotides in the same strand, ω is the optical frequency of the linear approximation, $q = 2\pi/\lambda$ is the wave number whose role will be discussed later, cc represents complex conjugate terms and the function F_0 is real. A mathematical basis for the expression (3.10) is a multiple-scale method or a derivative-expansion method [9, 38].

From (3.10) one can see the true meaning of the parameter ε . The higher order terms are required because of the last two terms in (3.8). The function F_1 represents the envelope which will be treated in a continuum limit while the carrier component $e^{i\theta_n}$ will not. Hence, this is the carrier component which includes discreteness and the expression (3.10) is called the semi-discrete approximation. As the frequency of the carrier wave is much higher than the frequency of the envelope we need two time scales, t and εt , for those two functions. Of course, the same holds for the coordinate scales.

Now, the Eq. (3.8) can be solved. It was already pointed out that the functions F_i would be treated in the continuum limit. Hence, taking this limit ($nl \rightarrow z$) and applying the transformations

$$Z = \varepsilon z; \quad T = \varepsilon t \tag{3.12}$$

one can straightforwardly obtain the following continuum approximation

$$F(\varepsilon(n \pm h)l, \varepsilon t) \rightarrow F(Z, T) \pm F_Z(Z, T)\varepsilon lh + \frac{1}{2}F_{ZZ}(Z, T)\varepsilon^2 l^2 h^2 \tag{3.13}$$

where indexes Z and ZZ denote the first and the second derivative with respect to Z [39]. This brings about a new expression for the function $\Phi_n(t)$

$$\begin{aligned} \Phi_n(t) &\rightarrow F_1(Z, T)e^{i\theta} + \varepsilon[F_0(Z, T) + F_2(Z, T)e^{i2\theta}] + cc \\ &= F_1e^{i\theta} + \varepsilon[F_0 + F_2e^{i2\theta}] + F_1^*e^{-i\theta} + \varepsilon F_2^*e^{-i2\theta} \end{aligned} \tag{3.14}$$

where $*$ stands for complex conjugate and $F_i \equiv F_i(Z, T)$. Hence, one can easily obtain the expression

$$\dot{\Phi}_n = \varepsilon F_{1T}e^{i\theta} - i\omega F_1e^{i\theta} + \varepsilon^2 F_{0T} + \varepsilon^2 F_{2T}e^{i2\theta} - 2i\varepsilon\omega F_2e^{i2\theta} + cc \tag{3.15}$$

as well as all the terms in (3.8), such as

$$\begin{aligned} &\Phi_{n+h} + \Phi_{n-h} + 2\Phi_n \\ &= \{2F_1[\cos(qhl) + 1] + 2i\varepsilon hl F_{1Z}\sin(qhl) + \varepsilon^2 h^2 l^2 F_{1ZZ}\cos(qhl)\}e^{i\theta} \\ &\quad + \{2\varepsilon F_2[\cos(2qhl) + 1] + 2i\varepsilon^2 hl F_{2Z}\sin(2qhl)\}e^{i2\theta} + 4\varepsilon F_0 + cc \end{aligned} \tag{3.16}$$

and

$$\Phi_n^3 = 3|F_1|^2 F_1 e^{i\theta} + 3|F_1|^2 F_1^* e^{-i\theta} + F_1^3 e^{i3\theta} + F_1^{*3} e^{-i3\theta} + O(\varepsilon). \tag{3.17}$$

All this brings about the continuum version of (3.8). This crucial expression is

$$\begin{aligned} &(\varepsilon^2 F_{1TT} - 2i\varepsilon\omega F_{1T} - \omega^2 F_1)e^{i\theta} - (4i\varepsilon^2\omega F_{2T} + 4\varepsilon\omega^2 F_2)e^{i2\theta} + cc \\ &= \frac{k}{m}\{2F_1[\cos(ql) - 1]e^{i\theta} + 2i\varepsilon l F_{1Z}\sin(ql)e^{i\theta} + \varepsilon^2 l^2 F_{1ZZ}\cos(ql)e^{i\theta} \\ &\quad + 2\varepsilon F_2[\cos(2ql) - 1]e^{i2\theta} + 2i\varepsilon^2 l F_{2Z}\sin(2ql)e^{i2\theta} + cc\} \\ &\quad - \frac{K}{m}\{2F_1[\cos(qhl) + 1]e^{i\theta} + 2i\varepsilon hl F_{1Z}\sin(qhl)e^{i\theta} + \varepsilon^2 h^2 l^2 F_{1ZZ}\cos(qhl)e^{i\theta} \\ &\quad + 2\varepsilon F_2[\cos(2qhl) + 1]e^{i2\theta} + 2i\varepsilon^2 hl F_{2Z}\sin(2qhl)e^{i2\theta} + 4\varepsilon F_0 + cc\} \end{aligned}$$

$$\begin{aligned}
 & -\omega_g^2[F_1 e^{i\theta} + \varepsilon F_0 + \varepsilon F_2 e^{i2\theta} + 2\varepsilon\alpha|F_1|^2 + 2\varepsilon^2\alpha(F_0 F_1 + F_1^* F_2) e^{i\theta} \\
 & + \varepsilon\alpha F_1^2 e^{i2\theta} + 2\varepsilon^2\alpha F_1 F_2 e^{i3\theta} + 3\varepsilon^2\beta|F_1|^2 F_1 e^{i\theta} + \varepsilon^2\beta F_1^3 e^{i3\theta} + \text{cc}], \tag{3.18}
 \end{aligned}$$

representing a starting point for a couple of important expressions. These formulae can be obtained equating the coefficients for the various harmonics [33, 39].

Equating the coefficients for $e^{i\theta}$, one obtains

$$\begin{aligned}
 & \varepsilon^2 F_{1TT} - 2i\varepsilon\omega F_{1T} - \omega^2 F_1 \\
 & = \frac{k}{m}[2F_1(\cos(ql) - 1) + 2i\varepsilon l F_{1Z} \sin(ql) + \varepsilon^2 l^2 F_{1ZZ} \cos(ql)] \\
 & \quad - \frac{K}{m}[2F_1(\cos(qhl) + 1) + 2i\varepsilon hl F_{1Z} \sin(qhl) + \varepsilon^2 h^2 l^2 F_{1ZZ} \cos(qhl)] \\
 & \quad - \omega_g^2[F_1 + 2\varepsilon^2\alpha F_0 F_1 + 2\varepsilon^2\alpha F_1^* F_2 + 3\varepsilon^2\beta|F_1|^2 F_1]. \tag{3.19}
 \end{aligned}$$

Neglecting all the terms with ε and ε^2 we get a dispersion relation

$$\omega^2 \equiv \omega_y^2 \equiv \omega_o^2 = (4/m)[a^2 D + k \sin^2(ql/2) + K \cos^2(qhl/2)], \tag{3.20}$$

which brings about the expression for the group velocity $d\omega/dq$ as

$$V_g = \frac{l}{m\omega}[k \sin(ql) - Kh \sin(qhl)]. \tag{3.21}$$

A corresponding dispersion relation for the in-phase oscillations described by (3.5) is

$$\omega_x^2 \equiv \omega_a^2 = (4/m)[k \sin^2(ql/2) + K \sin^2(qhl/2)]. \tag{3.22}$$

The frequencies ω_y and ω_x are usually called optical and acoustical.

In the same way, equating the coefficients for $e^{i0} = 1$, one can easily obtain

$$F_0 = \mu|F_1|^2; \quad \mu = -2\alpha\left(1 + \frac{4K}{m\omega_g^2}\right)^{-1}. \tag{3.23}$$

Both remaining coefficients ($e^{i2\theta}$ and $e^{i3\theta}$) give a formula

$$F_2 = \delta F_1^2 \tag{3.24}$$

but with different values for the parameter δ . First attempts were carried out assuming a simple version that is $\delta = -\beta/2\alpha$, coming from $e^{i3\theta}$ [40]. However, a more physically-based approach, using the terms for the more influential lower harmonic, should be better [41]. Hence, equating the coefficients for $e^{i2\theta}$ and neglecting all the terms with ε^2 and smaller, one obtains the nonconstant δ

$$\delta = \omega_g^2\alpha\left[4\omega^2 - \frac{2k}{m}(1 - \cos(2ql)) - \frac{2K}{m}(1 + \cos(2hql)) - \omega_g^2\right]^{-1}, \tag{3.25}$$

depending on ql . This expression will be used throughout this paper.

As the functions F_0 and F_2 can be expressed through F_1 the equation for F_1 should be derived. Using new coordinates again

$$S = Z - V_g T, \quad \tau = \varepsilon T, \tag{3.26}$$

one obtains the transformations for F_{1Z} , F_{1ZZ} , F_{1T} and F_{1TT} such as $F_{1Z} = F_{1S}$, $F_{1T} = -V_g F_{1S} + \varepsilon F_{1\tau}$, etc. The meaning of (3.26), as well as of (3.12), will be discussed later. Using equations (3.19)–(3.21), (3.23), (3.24) and (3.26) one can easily obtain the well-known nonlinear Schrödinger equation (NLSE) for the function F_1

$$iF_{1\tau} + PF_{1SS} + Q|F_1|^2 F_1 = 0 \tag{3.27}$$

where the dispersion coefficient P and the coefficient of nonlinearity Q are given by

$$P = \frac{1}{2\omega} \left\{ \frac{l^2}{m} [k \cos(ql) - Kh^2 \cos(ghl)] - V_g^2 \right\}, \quad Q = -\frac{\omega_g^2}{2\omega} [2\alpha(\mu + \delta) + 3\beta]. \tag{3.28}$$

An analytical solution of the NLSE exists. For $PQ > 0$ the solution of (3.27) is [6, 33, 42]

$$F_1(S, \tau) = A_0 \operatorname{sech} \left(\frac{S - u_e \tau}{L_e} \right) \exp \frac{i u_e (S - u_e \tau)}{2P}. \tag{3.29}$$

Throughout this paper it will be assumed that $P > 0$ and $Q > 0$ [42]. The envelope amplitude A_0 and its width L_e have the forms

$$A_0 = \sqrt{\frac{u_e^2 - 2u_e u_c}{2PQ}}, \quad L_e = \frac{2P}{\sqrt{u_e^2 - 2u_e u_c}}, \quad u_e > 2u_c. \tag{3.30}$$

The function (3.29) is the modulated solitonic wave where u_e and u_c are the velocities of the envelope and the carrier waves, respectively.

Now, the expression for $y_n(t)$, defined by (3.7) and (3.10), can be easily obtained. However, before we proceed the parameters existing in the HPB model should be discussed. There are two groups of them. One group are so-called intrinsic parameters describing the geometry and the chemical interactions within DNA. These are: k , K , a , D and $q = 2\pi/\lambda$ and their values will be discussed later.

The second group are the parameters coming from the applied mathematical procedure. These mathematical parameters are: u_e , u_c and ε . The velocities u_e and u_c are included in the solution of the NLSE. On the other hand, ε does not have any physical meaning. This is nothing but a “working” parameter, helping us to distinguish big and small terms in the series expansion (3.10). Hence, one would expect that DNA dynamics does not depend on it. In other words, ε exists in the derivations but is not expected to determine the final solution $y_n(t)$. A careful investigation of all the formulae shows that only two mathematical parameters are relevant and they are: εu_e and εu_c . Also, it is important to notice that the last part of (3.30) is very difficult to deal with. This is why it is more convenient to introduce new mathematical parameters U_e and η defined as [43]

$$U_e = \varepsilon u_e, \quad \eta = \frac{u_c}{u_e}, \quad 0 \leq \eta < 0.5. \tag{3.31}$$

We will return to this point later and show how U_e can be expressed through η . This, practically, means that η remains the single mathematical parameter.

Everything is prepared now for the final expression of the solution of (3.6). According to the expressions (3.7), (3.10)–(3.12), (3.23), (3.24), (3.26) and (3.29)–(3.31) the stretching of the nucleotide pair at the position n is

$$y_n(t) = 2A \operatorname{sech}\left(\frac{nl - V_e t}{L}\right) \left\{ \cos(\Theta nl - \Omega t) + A \operatorname{sech}\left(\frac{nl - V_e t}{L}\right) \left[\frac{\mu}{2} + \delta \cos(2(\Theta nl - \Omega t)) \right] \right\} \quad (3.32)$$

where

$$A \equiv \varepsilon A_0 = U_e \sqrt{\frac{1 - 2\eta}{2PQ}}, \quad L \equiv \frac{L_e}{\varepsilon} = \frac{2P}{U_e \sqrt{1 - 2\eta}}. \quad (3.33)$$

The envelope velocity V_e , the wave number Θ and the frequency Ω are given by

$$V_e = V_g + U_e, \quad \Theta = q + \frac{U_e}{2P}, \quad \Omega = \omega + \frac{(V_g + \eta U_e)U_e}{2P}. \quad (3.34)$$

To plot the function $y_n(t)$ the values of all the parameters should be known. It was already indicated that there were the two groups of them, mathematical (U_e, η) and intrinsic parameters (k, K, a, D, q). The problem with the mathematical parameters has practically been solved using the idea of a coherent mode (CM), assuming that the envelope and the carrier wave velocities are equal, i.e. [44]

$$V_e = \frac{\Omega}{\Theta}. \quad (3.35)$$

This means that the function $y_n(t)$ is the same at any position n . In other words, the wave preserves its shape in time, indicating high stability [43]. This sort of stability suggests that this mode is the most favourable one, i.e. the one representing the best description of DNA dynamics in the context of the aforementioned model. Notice that (3.35) ensures that (3.32) becomes one phase function. From the requirement (3.35) one can easily obtain the function $U_e(\eta)$, which is

$$U_e = \frac{P}{1 - \eta} \left[-q + q \sqrt{1 + \frac{2(1 - \eta)}{Pq^2}(\omega - qV_g)} \right]. \quad (3.36)$$

This is a slowly increasing function of η [43]. Hence, there is only one mathematical parameter left. It was shown that only the values of η close to its maximum have physical meaning [43]. Otherwise, DNA would not be stable. Hence, it was estimated that η should be close to 0.5 and is certainly bigger than 0.4 [43].

The CM has a deeper meaning. It was mentioned above that (3.32) is the one phase function if (3.35) is assumed. This means that $y_n(t)$ depends on nl and t through $\xi = nl - V_e t$, where V_e is a constant, representing the travelling wave. Therefore, $y_n(t)$, obviously being localized, satisfy all the requirements for the solitonic wave as explained in Sec. 2. This means that the CM is nothing but the solitonic mode (SM).

To deal with the values of the intrinsic parameters is extremely important but very difficult task. The only satisfactory solution would be if all the values were determined experimentally. Unfortunately, this has not been done yet. This means that, for now, we

should be satisfied with their estimations only. As a result of these estimations only accepted intervals of the values of the parameters are known. Of course, increasing knowledge brings about shorter intervals. Finally, a certain combination should be picked up. This makes possible to plot the function $y_n(t)$, to calculate the solitonic speed V_e , its width Λ , etc. According to the figure one can recognise the amplitude of the stretching, the value of the solitonic width and so on. If all these values have physical meaning and if the calculated velocity V_e matches the experimental value one can conclude that the choice of the values of the parameters was probably correct. However, one should be careful as different combination may bring about more or less equal results.

In what follows some estimations having been carried out so far will be presented. The only approach that may bring about a satisfactory conclusion is a combination of the estimations based on both theoretical and experimental results and their careful analysis.

The values of a and D were estimated according to some experimental data [44]. The highest values for a product aD were estimated to be around 150 pN [45], 108 pN [46] or, even, smaller [47, 48]. According to a theoretical paper [49] this product was estimated to be about 140 pN [44]. Also, it was indicated that only small values of a are compatible with the HPB model [44]. Otherwise, the series expansion of the exponential function in the Morse potential would not be possible. Hence, it was concluded that the values existing in the literature were overestimated and the values close to $1\text{A}^{\circ-1}$ or, even, smaller were suggested [44]. An experiment proposal to determine the values of these two parameters was explained recently [50].

Let us study the possible values for the wave number q . The values found in literature are from $q = 0.01\text{A}^{\circ-1}$ [33] to $q = 0.39\text{A}^{\circ-1}$ [51] without any arguments. It was suggested that the corresponding wave length covers an integer number of the periods l [40], i.e.

$$q = \frac{2\pi}{\lambda}, \quad \lambda = Nl, \quad N \text{ integer.} \quad (3.37)$$

Hence, one can assume N as the internal parameter instead of q or λ . According to some requirements ($P > 0$, $Q > 0$) a couple of small values of N have been excluded [52]. The upper limit was estimated and the suggested interval became [52]

$$7 \leq N \leq 20, \quad (3.38)$$

which corresponds to $0.09\text{A}^{\circ-1} \leq q \leq 0.26\text{A}^{\circ-1}$ as the well known value for the distance between the two neighbouring nucleotides belonging to the same strand is $l = 0.34 \text{ nm}$.

A variety of the values of the parameter k can be found in literature. The ratio of the biggest and the smallest of them would be above 1000! According to rather detailed analysis it was shown that most of these values have been underestimated [53]. Also, an experiment proposal that could bring about its value or, to be more precise, very short interval for k , was suggested [53]. Ratios k/K and K/a^2D , as well as a maximum of K , were studied recently [52].

All these efforts yield rather narrow intervals for the internal parameters. One example, satisfying the experimental value for the solitonic speed [54], could be [52]

$$a = 1.2\text{A}^{\circ-1}, \quad D = 0.07 \text{ eV}, \quad k = 12 \text{ N/m}, \quad K = 0.08 \text{ N/m}, \quad N = 10, \quad \eta = 0.47. \quad (3.39)$$

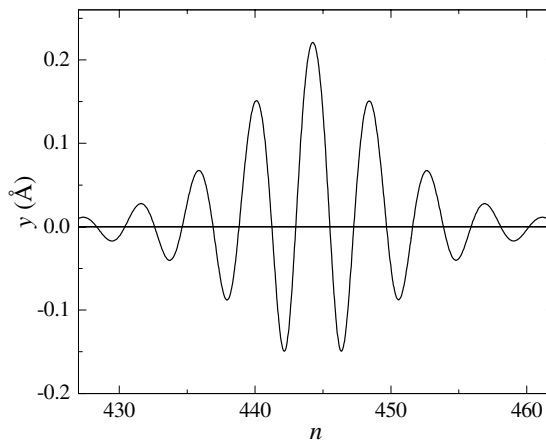

Fig. 8. The nucleotide pair stretching at $t = 80$ ps for: $a = 1.2\text{\AA}^{\circ-1}$, $D = 0.07$ eV, $k = 12$ N/m, $K = 0.08$ N/m, $N = 10$ and $\eta = 0.47$.

With these values and using the values for l , m and h that were mentioned above the nucleotide pair stretching as a function of the position is obtained and shown in Fig. 8.

It is obvious that this is a localised modulated wave. It was argued above that this wave satisfied all the criteria to be the solitonic one as the CM, i.e. the SM, was assumed. However, there is not a unique definition of the solitons except the one rather imprecise working definition saying that solitons are so stable that they emerge from a collision having the same shapes and velocities with which they entered. Hence, it would be interesting if the wave characteristics were studied experimentally. It was suggested recently how to study stability of the wave during its propagation along DNA [55]. However, as was stated above, by stability we usually mean how the waves behave upon collision. To study this characteristic we need two waves. An experiment proposal to detect the waves before and after their collision was presented recently [55]. In addition, it was suggested how to experimentally determine the solitonic width Λ [55] and its speed V_e [56]. The goal of these experiments would be not only to determine these values but to study how V_e and Λ depend on the wave amplitude, i.e. on the initial stretching of the chosen base pair. Namely, a typical characteristic of the solitons is the fact that the higher soliton is shorter and moves faster, as explained in Sec. 2.

The experiments mentioned above are micromanipulating experiments. Namely, it is possible to extract a DNA molecule from a cell and perform its mechanical manipulation such as twisting, stretching and so on. The first such experiment was carried out in 1992 [57]. From then, a few techniques have been used for this kind of research. The mentioned work has been the bases for a number of papers studying various elastic properties of DNA [45–48, 58–64]. Those experiments were followed by theoretical research, numerical simulations and review papers [35, 36, 65–69]. Note that some other molecules like sugars, RNA, proteins, have been investigated using the micromanipulation techniques.

The solitonic width, corresponding to Fig. 8, is about 30 nucleotide pairs. As was mentioned above the appropriate experimental values do not exist. However, this width can be compared with the solitonic width at a DNA segment involved in a process of transcription. It was reported [70] that this width is between 8 and 17 nucleotides. Some experimental

investigations suggest that this segment covers between 7 and 15 base pairs [71]. Obviously, the width shown in Fig. 8 is higher. However, we should keep in mind that the transcription is followed by a local unzipping, which can be understood as an extremely high amplitude. It is well known that transcription occurs only at the segments where DNA is surrounded by m-RNA polymerase (RNAP). Hence, the wave shown in Fig. 8 is an “ordinary” one, while the solitons at the mentioned segments have much higher amplitudes, corresponding to the local unzipping, which is a topic of the next section. As the increase of the amplitude means the decrease of the solitonic width we can conclude that the solitonic width, corresponding to Fig. 8, makes sense.

According to Fig. 8, one can see that the positive amplitude is a little bit bigger than the negative one. This is coming from the higher order term in (3.32). Basically, this is a result of the fact that the Morse potential is not symmetric, which means that the repulsive force between the nucleotides is stronger than the attractive one.

3.3. *Local opening of DNA*

Any model is good, more or less, if it can explain something. The HPB model can explain the local opening of DNA. This is a well known fact which happens during transcription.

The frequencies (3.20) and (3.22) were compared [33, 72]. One can notice that $\omega_y > \omega_x$ if $K < a^2D$. For $K = a^2D$ these frequencies are equal at $ql = \pi/h$ and it was suggested that this could represent a resonance mode (RM) [72]. Notice that this value of ql is relevant for the assumed values of h and N , i.e. for $h = 5$ and $N = 10$, which was explained above. This mode was studied in more details [73, 74]. Before we proceed, one important point should be discussed. Does it make sense to compare these two frequencies as the corresponding equations (3.5) and (3.6) are decoupled? These equations are decoupled due to the mathematical trick, i.e. the good choice of the coordinates (3.4). One should keep in mind that ω_o and ω_a are not decoupled in a sense that they can be changed independently. This is so because both frequencies depend on the same parameters k and K . Hence, they are coupled through the common parameters.

A key point to understand is that local opening happens only at the segment where the DNA chain is surrounded by RNAP molecules. At these segments the transcription occurs which is nothing but the formation of m-RNA molecule from RNAP. Due to the RNAP the interaction between the nucleotides belonging to the same pair is changed. This means that the Morse potential at these segments is different from the potential at the rest of the molecule. It is obvious that, for Fig. 8, i.e. for the values (3.39), the optical frequency is higher than the acoustical one as $a^2D > K$. It was explained that, at the segments mentioned above, the decrease of a and D brings about the equality of a^2D and K [73]. Of course, it was shown that the amplitude becomes infinitely large when the values of these two frequencies approach each other and this was called as extremely high amplitude (EHA) mode [73]. Also, the positive amplitude in Fig. 8 becomes bigger while the negative one decreases and, finally, only the positive amplitude remains covering about 10 nucleotide pairs, which represents the local opening [73]. Some additional arguments were offered and it was suggested that the EHA mode is nothing but the RM [74].

A patient reader might have noticed that the real optical frequency is Ω rather than ω_y . This is correct and, in fact, these two frequencies were compared [73], while the explanation given above is simplified.

Notice that a quantitative treatment is not possible as the HPB model assumes the small oscillations. Also, the infinitely large amplitude in the case of RM should not bother us as the frictional forces have been neglected so far. A more realistic approach, taking viscosity into consideration, is explained in the next section.

3.4. The HPB model including viscosity

The impact of the medium can be taken into consideration by adding a viscous force

$$F_v = -\gamma \dot{y}_n \tag{3.40}$$

to the equation of motion (3.6) where γ represents a damping coefficient [75–77]. In (3.10) and (3.11) θ_n and ω should be replaced by $\theta_{n\gamma} \equiv \theta_\gamma$ and ω_γ and $q_\gamma = q$ is assumed, which will be verified later. It is convenient to express the damping coefficient in units of 10^{-11} kg/s [40] and to introduce a parameter χ as

$$\gamma = g \cdot 10^{-11} \text{kg/s}; \quad \chi = \gamma/2m. \tag{3.41}$$

Following the procedure explained in Subsec. 3.2 one can obtain a new term in the basic equation (3.18), which is

$$NT = [-\varepsilon F_{1T} e^{i\theta_\gamma} + i\omega_\gamma F_1 e^{i\theta_\gamma} - \varepsilon^2 F_{0T} - \varepsilon^2 F_{2T} e^{i2\theta_\gamma} + 2i\varepsilon\omega_\gamma F_2 e^{i2\theta_\gamma}] \frac{\gamma}{m} + cc \tag{3.42}$$

and Eqs. (3.20), (3.21) and (3.25) become

$$\omega_\gamma^2 = \omega^2 - i2\chi\omega_\gamma, \quad V_\gamma \equiv V_{g\gamma} = \frac{l}{m} \frac{k \sin(ql) - Kh \sin(qhl)}{\omega_\gamma + i\chi}, \tag{3.43}$$

$$\delta_\gamma = \omega_g^2 \alpha [4\omega_\gamma^2 - \Delta + i4\chi\omega_\gamma]^{-1}, \quad \Delta = \frac{4}{m} [k \sin^2(ql) + K \cos^2(hql)] + \omega_g^2. \tag{3.44}$$

Notice that ω in (3.43) is the same as ω in (3.20) as $q_\gamma = q$ is assumed. Equations (3.23) and (3.24) are not affected by the new term (3.42).

For $\omega > \chi$ Eqs. (3.21) and (3.43) bring about

$$\omega_\gamma + i\chi = \sqrt{\omega^2 - \chi^2}, \quad V_\gamma = \frac{\omega V_g}{\sqrt{\omega^2 - \chi^2}}. \tag{3.45}$$

A derivation of NLSE is a tedious but a straightforward job. The new coordinates (3.26) should be used again, i.e.

$$S_\gamma \equiv S = Z - V_\gamma T, \quad \tau = \varepsilon T, \tag{3.46}$$

which brings about

$$i(\omega_\gamma + i\beta)F_{1\tau} + \frac{1}{2} \left\{ \frac{l^2}{m} [k \cos(ql) - Kh^2 \cos(qhl)] - V_\gamma^2 \right\} F_{1SS} - \frac{\omega_g^2}{2} [2\alpha(\mu + \delta_\gamma) + 3\beta] |F_1|^2 F_1 = 0. \tag{3.47}$$

Hence, using (3.45) one obtains the final expression for NLSE, which is

$$iF_{1\tau} + P_\gamma F_{1SS} + Q_\gamma |F_1|^2 F_1 = 0 \tag{3.48}$$

with the appropriate parameters being

$$P_\gamma = \frac{1}{2\sqrt{\omega^2 - \chi^2}} \left\{ \frac{l^2}{m} [k \cos(ql) - kh^2 \cos(qhl)] - V_g^2 \right\} \quad (3.49)$$

and

$$Q_\gamma = -\frac{\omega_g^2}{2\sqrt{\omega^2 - \chi^2}} [2\alpha(\mu + \delta_\gamma) + 3\beta]. \quad (3.50)$$

A key point is the fact that the nonlinear parameter Q_γ is complex, which means that (3.48) should be solved numerically. It is convenient to separate the real and the imaginary parts of the expression for Q_γ . Using (3.44) and (3.50) one can straightforwardly obtain

$$Q_\gamma = -\frac{\omega_g^2 \alpha}{\sqrt{\omega^2 - \chi^2}} (Q_1 + iQ_2) \equiv Q_r + iQ_i, \quad (3.51)$$

where

$$Q_1 = \mu + CM + 1.5\frac{\beta}{\alpha}, \quad Q_2 = CN, \quad (3.52)$$

and

$$M = 4(\omega^2 - \chi^2) - \Delta, \quad N = \frac{2\gamma}{m} \sqrt{\omega^2 - \chi^2}, \quad C = \frac{\omega_g^2 \alpha}{M^2 + N^2}. \quad (3.53)$$

Notice that $Q_r > 0$ and $Q_i < 0$ [78].

There are two requirements that should be satisfied to determine the maximum of the parameter g . These are: $\omega > \chi$ and $P_\gamma > 0$. It was shown that the allowed interval is $0 < g < 0.372$ if (3.39) is assumed [79]. It was mentioned above that all this hold for $q_\gamma = q$, i.e. for the assumed value $N = 10$. The value for q can be obtained according to the requirements: $V_\gamma > 0$ and $P_\gamma > 0$. It is very easy to show that the allowed intervals are: $ql < 0.98$ for $g = 0$ and $g = 0.1$, $ql < 0.94$ for $g = 0.2$ and $ql < 0.86$ for $g = 0.3$. This means that $N = 10$ may be the good choice again.

Finally, (3.48) should be solved numerically and $y_n(t)$ can be obtained [79]. It was shown that viscosity destroys modulation which has very important biological implication. Namely, the DNA-RNA transcription is efficient if the maximum of $y_n(t)$ is big enough and if the interaction time between the nucleotides belonging to DNA and to RNAP lasts as long as possible. Of course, this time is bigger if the frequency is smaller and is the biggest possible for the demodulated wave [79]. In other words, the modulated wave shown in Fig. 8 moves through the DNA chain. When it reaches the segment where the chain is surrounded by RNAP viscosity, coming from RNAP itself, drastically changes DNA dynamics. The solitonic wave becomes demodulated which ensures long enough period of interaction between bases belonging to DNA and RNAP which brings about the DNA-RNA transcription. Of course, when the soliton passes this segment it becomes the modulated wave again [79].

Also, viscosity decreases the amplitude, which is something that one could expect. It is much more important that the amplitude of the demodulated signal is almost constant [79]. This certainly indicates post demodulation stability which is obviously suitable for the process of transcription.

4. Concluding Remarks

In this paper one of the nonlinear models describing DNA dynamics is explained. The basic equation is NLSE. We should keep in mind that the solution explained in this paper is not the only choice. For example, it is possible to express its solution using Jacobian elliptic functions. However, a recent comparison of the two approaches favors the one explained in this paper [80].

Also, viscosity can be introduced in a different way. In the treatment explained above the viscous force was considered as competitive with other forces arising from the Hamiltonian. However, there is an alternative approach where $F_v = -\varepsilon \gamma \dot{y}_n$ was introduced, which means that the viscous force has features of small perturbation. We refer them as “big” and “small” viscosities [39].

A patient reader might ask why the parameter ε exists in the time scaling in (3.26) and (3.46) but is not present in the space scaling. It was pointed out that the carrier component of the function (3.10) changes faster than the envelope functions F_i . This means that the small parameter ε is present only in the envelope components F_i and this is why the scaling (3.12) was introduced. On the other hand, the definition (3.26) ensures that the time variation of the envelope of the function F_1 , in units $1/\omega$, be smaller than its space variation in units l [81].

A key question in many branches of physics is quantum vs. classical treatment. The author gave a small contribution to this problem showing a possible advantage of the classical approach in nonlinear DNA dynamics [82].

Finally, a role of temperature should be discussed. Obviously, temperature variations were not taken into consideration in this paper. This does not mean that the HPB model neglects the influence of temperature on DNA dynamics. It is explained [33] that a mean value $\langle y \rangle$ is temperature dependent but $y_n(t)$ is not. Also, a physiological temperature, i.e. natural biological environment of DNA, was assumed. This means that the temperature variations are very small.

References

- [1] B. Alberts, D. Bray, J. Lewis, M. Raff, K. Roberts and J. D. Watson, *Molecular Biology of the Cell*, 3rd edn. (Garland Publishing, New York, 1994).
- [2] J. D. Watson, *Molecular Biology of the Gene*, 3rd edn. (W. A. Benjamin, Menlo Park, California, 1976).
- [3] M. V. Volkenstein, *Biofizika* (Nauka, Moskva, 1981) [in Russian].
- [4] W. Saenger, *Principles of Nucleic Acid Structure*, 2nd edn. (Springer, New York, 1988).
- [5] J. D. Watson and F. H. C. Crick, Molecular structure of nucleic acid, *Nature* **171** (1953) 737–738.
- [6] A. C. Scott, F. Y. F. Chu and D. W. McLaughlin, The soliton: A new concept in applied science, *Proc. IEEE* **61** (1973) 1443–1483.
- [7] G. L. Lamb, Jr., *Elements of Soliton Theory* (John Wiley & Sons, New York, 1980).
- [8] A. Das, *Integrable Models*, World Scientific Lecture Notes in Physics, Vol. 30 (World Scientific, Singapore, 1989).
- [9] R. K. Dodd, J. C. Eilbeck, J. D. Gibbon and H. C. Morris, *Solitons and Nonlinear Wave Equations* (Academic Press, London, 1982).
- [10] M. V. Satarić, D. Sekulić and M. Živanov, Solitonic ionic currents along microtubules, *J. Comput. Theor. Nanosci.* **7** (2010) 2281–2290.

- [11] L. V. Yakushevich, *Nonlinear Physics of DNA*, Wiley Series in Nonlinear Science (John Wiley, Chichester, 1998).
- [12] S. W. Englander, N. R. Kallenbach, A. J. Heeger, J. A. Krumhansl and S. Litwin, Nature of the open state in long polynucleotide double helices: Possibility of soliton excitations, *Proc. Natl. Acad. Sci. (USA)* **777** (1980) 7222–7226.
- [13] G. Gaeta, C. Reiss, M. Peyrard and T. Dauxois, Simple models of nonlinear DNA dynamics, *Rivista del Nuovo Cimento* **17** (1994) 1–48.
- [14] G. F. Zhou and C. T. Zhang, A short review on the nonlinear motion in DNA, *Phys. Scr.* **43** (1991) 347–352.
- [15] M. Barbi, S. Cocco and M. Peyrard, Helicoidal model for DNA opening, *Phys. Lett. A* **253** (1999) 358–369.
- [16] L. V. Yakushevich, Nonlinear DNA dynamics: A new model, *Phys. Lett. A* **136** (1989) 413–417.
- [17] L. V. Yakushevich, Nonlinear DNA dynamics: Hierarchy of the models, *Physica D* **79** (1994) 77–86.
- [18] L. V. Yakushevich, A. V. Savin and L. I. Manevitch, Nonlinear dynamics of topological solitons in DNA, *Phys. Rev. E* **66** (2002) 016614 (14 pages).
- [19] G. Gaeta, On a model of DNA torsion dynamics, *Phys. Lett. A* **143** (1990) 227–232.
- [20] G. Gaeta, Solitons in planar and helicoidal Yakushevich model of DNA dynamics, *Phys. Lett. A* **168** (1992) 383–390.
- [21] G. Gaeta, Solitons in the Yakushevich model of DNA beyond the contact approximation, *Phys. Rev. E* **74** (2006) 021921 (9 pages).
- [22] G. Gaeta, Composite model for DNA torsion dynamics, *Phys. Rev. E* **75** (2007) 021919 (21 page).
- [23] G. Gaeta, Solitons in Yakushevich-like models of DNA dynamics with improved intrapair potential, *J. Nonlinear Math. Phys.* **14** (2007) 57–81.
- [24] M. Daniel and V. Vasumathi, Perturbed soliton excitations in the DNA double helix, *Physica D* **231** (2007) 10–29.
- [25] V. Vasumathi and M. Daniel, Perturbed soliton-like molecular excitations in a deformed DNA chain, *Phys. Lett. A* **373** (2008) 76–82.
- [26] M. Daniel and V. Vasumathi, Solitonlike base pair opening in a helicoidal DNA: An analogy with a helimagnet and a cholesteric liquid crystal, *Phys. Rev. E* **79** (2009) 012901 (4 pages).
- [27] S. Yomosa, Soliton excitations in deoxyribonucleic acid (DNA) double helices, *Phys. Rev. A* **27** (1983) 2120–2125.
- [28] S. Yomosa, Solitary excitations in deoxyribonucleic acid (DNA) double helices, *Phys. Rev. A* **30** (1984) 474–480.
- [29] S. Homma and S. Takeno, A coupled base-rotator model for structure and dynamics of DNA, *Prog. Theor. Phys.* **72** (1984) 679–693.
- [30] C. B. Tabi, A. Mohamadou and T. C. Kofané, Discrete instability in the DNA double helix, *Chaos* **19** (2009) 043101 (13 pages).
- [31] V. Vasumathi and M. Daniel, Base-pair opening and bubble transport in a DNA double helix induced by a protein molecule in a viscous medium, *Phys. Rev. E* **80** (2009) 061904 (9 pages).
- [32] M. Peyrard and A. R. Bishop, Statistical mechanics of a nonlinear model for DNA denaturation, *Phys. Rev. Lett.* **62** (1989) 2755–2758.
- [33] T. Dauxois, Dynamics of breather modes in a nonlinear helicoidal model of DNA, *Phys. Lett. A* **159** (1991) 390–395.
- [34] T. Dauxois, M. Peyrard and A. R. Bishop, Entropy-driven DNA denaturation, *Phys. Rev. E* **47** (1993) R44–R47.
- [35] M. Peyrard, Nonlinear dynamics and statistical physics of DNA, *Nonlinearity* **17** (2004) R1–R40.
- [36] T. R. Strick, M. N. Dessinges, G. Charvin, N. H. Dekker, J. F. Allemand, D. Bensimon and V. Croquette, Stretching of macromolecules and proteins, *Rep. Prog. Phys.* **66** (2003) 1–45.

- [37] M. Remoissenet, Low-amplitude breather and envelope solitons in quasi-one-dimensional physical models, *Phys. Rev. B* **33** (1986) 2386–2392.
- [38] T. Kawahara, The Derivative-expansion method and nonlinear dispersive waves, *J. Phys. Soc. Japan* **35** (1973) 1537–1544.
- [39] S. Zdravković, J. A. Tuszyński and M. V. Satarčić, Peyrard–Bishop–Dauxois model of DNA dynamics and impact of viscosity, *J. Comput. Theor. Nanosci.* **2** (2005) 263–271.
- [40] S. Zdravković and M. V. Satarčić, The impact of viscosity on the DNA dynamics, *Physica Scripta* **64** (2001) 612–619.
- [41] S. Zdravković, M. V. Satarčić and J. A. Tuszyński, Biophysical implications of the Peyrard–Bishop–Dauxois model of DNA dynamics, *J. Comput. Theor. Nanosci.* **1** (2004) 171–181.
- [42] T. Dauxois and M. Peyrard, *Physics of Solitons* (Cambridge University Press, Cambridge, UK 2006).
- [43] S. Zdravković and M. V. Satarčić, Nonlinear Schrödinger equation and DNA dynamics, *Phys. Lett. A* **373** (2008) 126–132.
- [44] S. Zdravković and M. V. Satarčić, Single molecule unzipping experiments on DNA and Peyrard–Bishop–Dauxois model, *Phys. Rev. E* **73** (2006) 021905 (11 pages).
- [45] G. U. Lee, L. A. Chrisey and R. J. Colton, Direct measurement of the forces between complementary strands of DNA, *Science* **266** (1994) 771–773.
- [46] T. Boland and B. D. Ratner, Direct measurement of hydrogen bonding in DNA nucleotide bases by atomic force microscopy, *Proc. Natl. Acad. Sci. USA* **92** (1995) 5297–5301.
- [47] U. Bockelmann, B. Essevaz-Roulet and F. Heslot, Molecular stick-slip motion revealed by opening DNA with piconewton forces, *Phys. Rev. Lett.* **79** (1997) 4489–4492.
- [48] T. Strunz, K. Oroszlan, R. Schäfer and H-J. Güntherodt, Dynamic force spectroscopy of single DNA molecules, *Proc. Natl. Acad. Sci. USA* **96** (1999) 11277–11282.
- [49] S. Cocco, R. Monasson and J. F. Marko, Force and kinetic barriers to initiation of DNA unzipping, *Phys. Rev. E* **65** (2002) 041907 (23 pages).
- [50] S. Zdravković and M. V. Satarčić, Morse potential in DNA molecule — An experiment proposal, submitted to *Chin. Phys. Lett.*
- [51] C. B. Tabi, A. Mohamadou and T. C. Kofané, Wave propagation of nonlinear modes and formation of bubble in a two-component helicoidal lattice, *Eur. Phys. J. D* **50** (2008) 307–316.
- [52] S. Zdravković and M. V. Satarčić, Parameter selection in a Peyrard–Bishop–Dauxois model for DNA dynamics, *Phys. Lett. A* **373** (2009) 2739–2745.
- [53] S. Zdravković and M. V. Satarčić, Stacking interaction in DNA molecule, *J. Comput. Theor. Nanosci.* **7** (2010) 2031–2035.
- [54] M. B. Hakim, S. M. Lindsay and J. Powell, The speed of sound in DNA, *Biopolymers* **23** (1984) 1185–1192.
- [55] S. Zdravković and M. V. Satarčić, DNA dynamics–experiment proposals, *Phys. Lett. A* **373** (2009) 4453–4459.
- [56] S. Zdravković and M. V. Satarčić, Solitonic speed in DNA, *Phys. Rev. E* **77** (2008) 031906 (7 pages).
- [57] S. B. Smith, L. Finzi and C. Bustamante, Direct mechanical measurements of the elasticity of single DNA molecules by using magnetic beads, *Science* **258** (1992) 1122–1126.
- [58] S. B. Smith, Y. Cui and C. Bustamante, Overstretching B-DNA: The elastic response of individual double-stranded and single-stranded DNA molecules, *Science* **271** (1996) 795–799.
- [59] J. F. Allemand, D. Bensimon, R. Lavery and V. Croquette, Stretched and overwound DNA forms a pauling-like structure with exposed bases, *Proc. Natl. Acad. Sci. USA* **95** (1998) 14152–14157.
- [60] H. Clausen-Schaumann, M. Rief, C. Tolksdorf and H. E. Gaub, Mechanical stability of single DNA molecules, *Biophys. J.* **78** (2000) 1997–2007.
- [61] M. C. Williams, K. Pant, I. Rouzina and R. L. Karpel, Single molecule force spectroscopy studies of DNA denaturation by T4 gene 32 protein, *Spectroscopy* **18** (2004) 203–211.

- [62] T. Lionnet, S. Joubaud, R. Lavery, D. Bensimon and V. Croquette, Wringing out DNA, *Phys. Rev. Lett.* **96** (2006) 178102 (4 pages).
- [63] E. A. Galburt, S. W. Grill and C. Bustamante, Single molecule transcription elongation, *Methods* **48** (2009) 323–332.
- [64] F. Mosconi, J. F. Allemand, D. Bensimon and V. Croquette, Measurement of the torque on a single stretched and twisted DNA using magnetic tweezers, *Phys. Rev. Lett.* **102** (2009) 078301 (4 pages).
- [65] S. M. Bhattacharjee, Unzipping DNAs: Towards the first step of replication, *J. Phys. A: Math. Gen.* **33** (2000) L423–L428.
- [66] S. Cocco, R. Monasson and J. F. Marko, Force and kinetic barriers to unzipping of the DNA double helix, *Proc. Natl. Acad. Sci. USA* **98** (2001) 8608–8613.
- [67] M. C. Williams, I. Rouzina and V. A. Bloomfield, Thermodynamics of DNA interactions from single molecule stretching experiments, *Acc. Chem. Res.* **35** (2002) 159–166.
- [68] A. Lebrun and R. Lavery, Modeling extreme stretching of DNA, *Nucl. Acids Res.* **24** (1996) 2260–2267.
- [69] J. R. Moffitt, Y. R. Chemla, S. B. Smith and C. Bustamante, Recent advances in optical tweezers, *Annu. Rev. Biochem.* **77** (2008) 205–228.
- [70] J. Gelles and R. Landick, RNA polymerase as a molecular motor, *Cell* **93** (1998) 13–16.
- [71] U. Siebenlist, RNA polymerase unwinds an 11-base pair segment of a phage T7 promoter, *Nature* **279** (1979) 651–652.
- [72] S. Zdravković and M. V. Satarić, Optical and acoustical frequencies in a nonlinear helicoidal model of DNA molecules, *Chin. Phys. Lett.* **22** (2005) 850–852.
- [73] S. Zdravković and M. V. Satarić, High amplitude mode and DNA opening, *Europhys. Lett.* **78** (2007) 38004 (6 pages).
- [74] S. Zdravković and M. V. Satarić, Resonance mode in DNA dynamics, *Europhys. Lett.* **80** (2007) 38003 (6 pages).
- [75] M. V. Satarić, J. A. Tuszyński and R. B. Žakula, Kinklike excitations as an energy-transfer mechanism in microtubules, *Phys. Rev. E* **48** (1993) 589–597.
- [76] T. Das and S. Chakraborty, A generalized Langevin formalism of complete DNA melting transition, *Europhys. Lett.* **83** (2008) 48003 (6 pages).
- [77] C. B. Tabi, A. Mohamadou and T. C. Kofané, Modulated wave packets in DNA and impact of viscosity, *Chin. Phys. Lett.* **26** (2009) 068703 (4 pages).
- [78] S. Zdravković and M. V. Satarić, Impact of viscosity on DNA dynamics, *Chin. Phys. Lett.* **24** (2007) 1210–1213.
- [79] S. Zdravković, M. V. Satarić and L. Hadžievski, DNA–RNA transcription as an impact of viscosity, *Chaos* **20** (2010) 043141.
- [80] S. Zdravković and C. B. Tabi, Two possible approaches in Peyrard–Bishop–Dauxois model of DNA dynamics, *J. Comput. Theor. Nanosci.* **7** (2010) 1418–1424.
- [81] M. Remoissenet and M. Peyrard, Soliton dynamics in new models with parameterized periodic double-well and asymmetric substrate potentials, *Phys. Rev. B* **29** (1984) 3153–3166.
- [82] S. Zdravković, Heisenberg uncertainty principle and DNA dynamics, *Physics Essays* **18** (2005) 168–173.