

POSSIBILITY OF APPLICATION NUCLEAR MAGNETIC RESONANCE FOR MEASUREMENT OF FLUID-FLOW

by

**Nenad M. KARTALOVIĆ¹, Saška D. DJEKIĆ²,
Saša B. DJEKIĆ³, Dušan P. NIKEZIĆ^{4*}, and Uzahir R. RAMADANI⁴**

¹ Institute of Electrical Engineering "Nikola Tesla", Belgrade, Serbia

² Department of Laboratory Diagnostics "Health Center", Doboj, Bosnia and Herzegovina

³ Power Utility of Republic of Srpska Elektro Doboj a.d., Doboj, Bosnia and Herzegovina

⁴ Vinča Institute of Nuclear Sciences, National Institute of the Republic of Serbia,
University of Belgrade, Belgrade, Serbia

Scientific paper

<https://doi.org/10.2298/NTRP210614017K>

The paper considers the application of nuclear magnetic resonance for measurement of fluid-flow. The paper is of an experimental nature. Flowmeter based on nuclear magnetic resonance is extremely precise. The combined measurement uncertainty can be 0.1 %. Such a value of measurement uncertainty indicates that it is a matter of a deterministic and not of a stochastic quantity. This high degree of reliability of the method is theoretically and mathematically described. The paper presents a measurement scheme for flow measurement. Water flow measurement was performed on the principle of nuclear magnetic resonance and on the basis of tritiated water (which is considered to be the most accurate classical method). The obtained results show that the measurement of flow based on nuclear magnetic resonance is more accurate (especially at higher flow). This is explained by the higher inertial mass of HTO tritiated water molecules than the standard H₂O mass and the possible transition of tritiated water to H³HeO. In this way, it has been proven that tracing water based on nuclear magnetic resonance is the only real tracing of water by water. The obtained results show that tracing water with tritiated or heavy water is not tracing water by water which is explained by different inertial masses.

Key words: nuclear magnetic resonance, flowmeter, tritiated water

INTRODUCTION

Nuclear magnetic resonance (NMR) was discovered theoretically in 1939 [1, 2]. The theoretically assumed existence of NMR was confirmed on paraffin and water [3, 4]. The NMR testing indicated the possibility of its application in material testing and for precise measurements.

So far, nuclear magnetic resonance has found a large number of practical applications: testing the structure of complex molecules containing hydrogen atoms, measuring the humidity of materials, testing oil wells, absolute measurements of high-precision magnetic induction, modern diagnostic methods in medicine, etc. The application of NMR in medicine is undoubtedly of the greatest importance because it gives a visual representation of the soft parts of human body where X-ray diagnosis is unsuccessful.

The final width of the resonant *peak* is a consequence of inhomogeneity of the field at the sample site

and the influence of paramagnetic salts dissolved in water. The ions of paramagnetic salts (for example FeNO₃ or MnSO₄) are added to the water sample because they enhance the effects of NMR. The dissolved salts shorten the residence time of protons at a higher energy level, so the energy of protons is rapidly converted into heat. Thus, the substance absorbs the energy of the high-frequency field more intensively, which facilitates the induction of resonance.

Experiments for NMR are carried out by creating a very homogeneous magnetic field of constant induction B by means of a permanent magnet, or electromagnet. The material in which the NMR occurs, with a volume of a dozen cubic millimeters, is placed in a test tube around which a small coil is wound. The coil with the test tube is placed in a magnetic field so that the axis is perpendicular to the induction. In a magnetic field, protons are located at two hyperfine levels whose energy difference is determined by eq. (16) in the next chapter. Through the voltage with the test tube is passed an alternating current with high frequency. If the frequency of the alternating field is set to the value

* Corresponding author; e-mail: dusan@vin.bg.ac.rs

given by eq. (18) NMR occurs. Protons from the lower level, with the absorption of energy, move to a higher energy level, so the upper level becomes more populated than the lower. Next, interactions with the environment lead to spontaneous de-excitations by which the protons return to a lower level and that allows the described process to continue. Since the magnetic moment of electron is much larger than the magnetic moment of proton, it is necessary to cancel the magnetic moments of electron in the outer shell. Materials that meet this condition are *e. g.* water, heavy water, glycerin, etc. [5].

The following two chapters give the mathematical basis of the NMR process model. The focus of this paper is to examine the possibility of application for measuring fluid-flow.

MATHEMATICAL MODEL OF NUCLEAR MAGNETIC RESONANCE

Magnetic moment and gyromagnetic relationship of elemental particles

A closed straight contour with current I has a magnetic moment \vec{M} [NmT⁻¹] defined by the eq.

$$\vec{M} = I \vec{S} \quad (1)$$

where \vec{S} is the vector of the contour area. In an external homogeneous magnetic field \vec{B} , the mechanical torque \vec{T} [Nm] acts on the contour, determined by the vector product

$$\vec{T} = \vec{M} \times \vec{B} \quad (2)$$

The trajectory of an electron orbiting a nucleus can also be regarded as a single elementary current contour which possesses a magnetic moment. For example, in Bohr's model of the hydrogen atom, the contour current is

$$I = ef = e \frac{\omega}{2\pi} \quad (3)$$

where e is the elementary charge, and f – the circular frequency of the electron. The contour area is

$$S = r^2 \pi \quad (4)$$

From eqs. (3) and (4), the following expression is obtained for the magnetic moment of the electron

$$M = IS = e \frac{\omega r^2}{2} \quad (5)$$

In the study of elementary atomic particles, the gyromagnetic relationship, γ , is introduced as the ratio of magnetic moment, M , and angular momentum L

$$\gamma = \frac{M}{L} \quad (6)$$

During the circular motion of an electron, the angular momentum is

$$L = mvr = m\omega r^2 \quad (7)$$

Substituting the eqs. (5)-(7) the gyromagnetic ratio of the electron is obtained as

$$\gamma = \frac{M}{L} = \frac{e}{2m} = 8.79398 \cdot 10^{10} (1.1 \cdot 10^{-5}) [\text{HzT}^{-1}] \quad (8)$$

The gyromagnetic relationship is the apparent constant of an atomic particle. Knowing the gyromagnetic relationship, the magnetic moment is obtained by

$$M = \gamma L \quad (9)$$

According to the scientist Niels Bohr, angular momentum is quantized quantity $L = nh/2$, where h is the Planck constant and $n = 1, 2, 3, \dots$ is the quantum number. For the ground state $n = 1$ in the eq. (8) the elementary magnetic moment can be obtained as

$$M_B = \frac{eh}{4\pi m} \quad (10)$$

known as the Bohr magneton. The magnetic field acts on the current contour with a mechanical moment, eq. (2). By rotating the contour in a homogeneous magnetic field for the angle θ it performs the work

$$\Delta A(\theta) = \int_0^\theta T d\theta = \int_0^\theta MB \sin \theta d\theta = MB(1 - \cos \theta) \quad (11)$$

If the contour rotates by $\theta = 180^\circ$, the work that is converted into an increment of potential energy is

$$\Delta A_{\max} = \Delta E = 2MB \quad (12)$$

A current contour whose magnetic moment is parallel to the induction has a lower level of potential energy, while a contour with an antiparallel direction of the magnetic moment is at a higher energy level [6-8].

Influence of magnetic field on proton energy

According to quantum theory, a proton has the angular momentum $L_p = h/4$. Using the eq. (9) for the magnetic moment of the proton M_p is obtained

$$M_p = \gamma_p L_p = \gamma_p \frac{h}{4\pi} \quad (13)$$

where γ_p is the gyromagnetic ratio of the proton whose value is [9-11]

$$\gamma_p = 2.675141 \cdot 10^8 [\text{HzT}^{-1}] \quad (14)$$

In relation to the external magnetic field of induction B , the magnetic moment of the proton takes one of two possible directions – parallel or antiparallel. According to the eq. (13), the difference of the proton energy in these two states is

$$\Delta E = 2M_p B = \gamma_p \frac{h}{2\pi} B \quad (15)$$

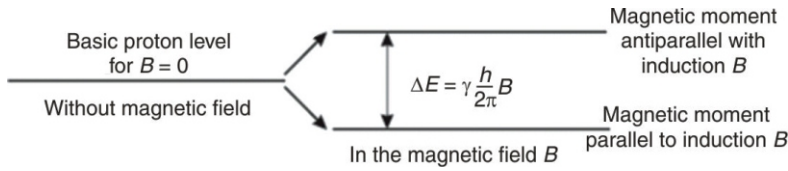

Figure 1. The interaction of the magnetic field with the magnetic moments of the proton creates two hyperfine energy levels

The separation of the basic energy level of a proton into two hyperfine levels due to the interaction of the magnetic field with the magnetic moment of the proton is shown in fig. 1. Higher and lower energy levels are approximately equally populated. The difference E corresponds to the frequency f determined by Planck's equation [12-15]

$$\Delta E = hf = \gamma \frac{h}{2\pi} B \quad (16)$$

From the eq. (16), the connection between frequency and magnetic induction was obtained

$$f = \frac{\gamma B}{2\pi} \text{ or } \omega = \gamma B \quad (17)$$

The eq. (17) is also used in the form

$$B = kf \quad (18)$$

wherein

$$k = 2.348731 \cdot 10^8 [\text{THz}^{-1}] \quad (19)$$

EXPERIMENT

Fluid flow measurement is based on the measurement of *overflight* time, *i. e.*, measuring the time it takes for a fluid to travel a certain distance. For this purpose, a tracer is inserted into the fluid. A tracer is a substance that differs from a fluid in some properties. The mean fluid velocity is assumed to be equal to the mean tracer velocity. This is an error, as the transport properties of the tracer are not the same as the transport properties of the fluid [16, 17]. There are optical, thermal, chemical, ionic, magnetic and radioactive tracers [18]. Brownian motion of a tracer and density changes during motion are, in addition to the previously mentioned different transport properties of fluids and tracers, a source of measurement uncertainty of the *overflight* time method [19-21].

In order to avoid all sources of measurement uncertainty using the *overflight* time method, the NMR method is proposed here. Nuclear magnetic resonance creates small magnetic tracers from molecules of the fluid itself, whose velocity is measured. This principle is completely independent of the behavior of the tracer, since the fluid is marked by itself. The magnetically traced volumes in this way are passive in the hydrodynamic view, so their velocity is identical to the velocity of the fluid.

To test this possibility, a flowmeter was made according to the scheme shown in fig. 2. The basic parts of an experimental flowmeter are:

- pipe expansion with a magnet for magnetizing fluids,
- magnet with coil for demagnetization of a small volume on the principle of NMR, by the action of a short high-frequency pulse, and
- a magnetic circuit with a coil to detect the passage of a traced volume of fluid (by applying commercial measuring instruments based on a giant magnetoresistance effect).

The electronic part of the system consists of:

- high-frequency generator whose frequency $f = B_2/2\pi$ corresponds to NMR at the site of the permanent induction magnet B2 (by using a professional frequency meter with measurement uncertainty type B 0.5 % given by the manufacturer),
- fast switch for generating a high-frequency magnetic pulse that demagnetizes a small volume of fluid, and
- a timer that measures the interval Δt between the generation of a high-frequency pulse and the passage of the traced volume next to the detection coil (according to the manufacturer, the measurement uncertainty type B of the timer is less than 0.5 %).

Then the fluid velocity can be calculated as $v = L/\Delta t$, where L is the coil distance for magnetization and detection.

In order to achieve the best possible result (*i. e.*, complete magnetization of the fluid), the volume of

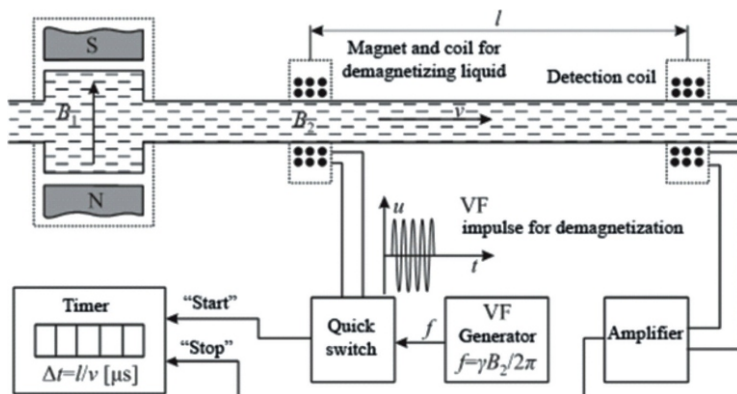

Figure 2. Block diagram of a system for measuring the velocity of a fluid (volume flow) based on the measurement of the overflight time using nuclear magnetic resonance for tracing fluid samples

the first chamber V_k is dimensioned so that the fluid stays in it for an average time equal to three times of the constant time for establishing magnetization. The combined measurement uncertainty is expressed at less than 1 %. Such a small value of expressed combined measurement uncertainty should not come as a surprise because measurement uncertainty type A, determined by processing a statistical sample of 100 random variables *flow rate*, was zero. The detection (not measurement) of magnetic induction based on a giant magnetoresistance effect corresponds to measurement uncertainty type B 0 (zero). Since the frequencies (and time) are physical quantities that measure with minimal values of measurement uncertainty type B, the manufacturer's data look credible.

RESULTS

The experimental verification of the method was performed by measuring the water flow rate. The experimentally obtained results were statistically treated. To form one statistical sample of a random variable *flow rate*, 100 consecutive measurements were performed by the NMR method. The time between the two measurements was 10 minutes. Chauvenet's criterion, to dismiss the suspicious results, was applied on the obtained statistical sample. There were no suspicious results and the results indicated that the random variable *flow rate* (conditionally speaking) was of the deterministic type in the case of NMR measurements. This conclusion was confirmed by determining the parameters of the possible distribution by the moment method. Since all moments of higher order had a value of zero, the statistical uncertainty of this conclusion is also zero.

Statistical analysis of a statistical sample, of random variable *flow rate* obtained by applying tritiated water, gave slightly weaker results. However, the obtained statistical uncertainty, by the same procedure, shows that even for the random variable *flow rate* of the tritiated water is also a deterministic quantity. This conclusion is correct with a statistical uncertainty less than 1 %, so that the stochasticity of the random variable *flow rate*, obtained by this method, can be neglected [22, 23].

A comparison of the proposed method with an NMR-based flowmeter and a tritium-based flowmeter was performed [24]. Tracing water with tritium is similar to NMR tracing, *i. e.*, tracing water with water. Tritium unites into an HTO water molecule that behaves almost identically to the molecule H_2O . However, this behavior is not identical since the inertial mass of HTO is two mass units greater than mass of H_2O . Also, since tritium is an unstable isotope of hydrogen, it can convert to H^3HeO during the measurement, which changes its transport properties. In addition, the tracing of water with tritium is the best of all classic tracers. It may be better to trace water with deuterium but,

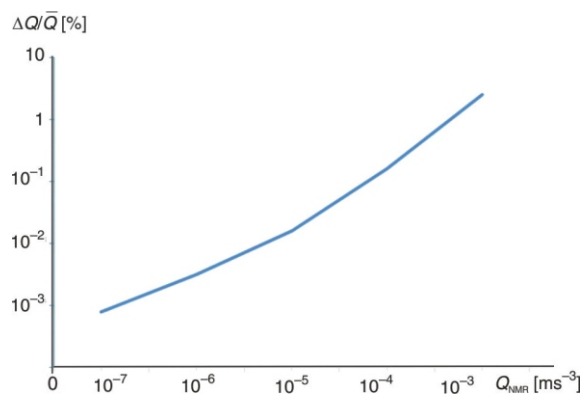

Figure 3. Dependence graph of the relative difference of the same water flow measured by NMR (Q_{NMR}) and tritiated water (Q_T) divided by the mean flow value

metrologically it would be complicated, as it would involve mass spectrometry. It should be noted that the tracing of water with tritium is also metrologically complicated as it is a measurement of low-energy radiation.

Figure 3 shows the dependence of the relative difference of the same water flow measured by NMR (Q_{NMR}) and tritiated water (Q_T), *i. e.*

$$\frac{\Delta Q}{\bar{Q}} = \frac{Q_{NMR} - Q_T}{2} \cdot \frac{Q_T}{Q_{NMR} Q_T} \quad (20)$$

It is clear from fig. 3 that the tritium-measured flows deviate to lower values at higher flows, which is certainly a consequence of the higher inertial mass of tritiated water molecules. The diagram in fig. 3 indisputably proves that the applied flow measurement method is superior to classical methods.

DISCUSSION

The presented result shows that in the case of a liquid with paired all the electrons of the outer shell (when NMR is detectable), an almost absolutely accurate measurement of the velocity, or amount of flow, can be performed. The reason for this result is the independence of the inertial properties of water molecules from the state of hyperfine magnetic excitation or de-excitation. Tritiated water does not have this property, nor does heavy water, since their atomic masses (which are inertial in nature) are three or two atomic mass units greater than the mass of ordinary water. In some other applications, testing tritiated (and/or heavy) water can provide a range of important data that cannot be obtained by NMR. Tritiated and heavy water are found in nature and they follow the hydrologic (water) cycle. Their concentration in water is associated with certain seasonal effects as well as the time spent outside of the atmospheric conditions. This enables monitoring and reliable verification of communication of atmospheric

(rainwater), surface water and groundwater. Test methods for the tritiated water and heavy water also allow to determine the age of groundwater that is excluded from the water circulation system in nature.

CONCLUSIONS

So far, NMR has found a large number of practical applications such as:

- examining the structure of complex molecules containing hydrogen atoms;
- absolute measurements of high-accuracy magnetic induction;
- measuring the humidity of materials;
- testing of oil wells;
- modern diagnostic methods in medicine, etc.

The applications of NMR in medicine are undoubtedly of the greatest importance because they enable obtaining a visual representation of the soft parts of the human body, where X-ray diagnostics are not successful. The NMR-based flowmeters are complex measuring devices that are used in exceptional conditions, *i. e.*, in conditions where high precision is required. They can be applied only in the nuclei possessing a magnetic moment. The application of NMR method does not depend on the chemical and electrical characteristics of the fluid. This measurement principle is used in biology and medicine. It can be argued with certainty that this is the most accurate method, with extremely small measurement uncertainties that can be 0.1 % and rarely exceed 2 %. The method discussed in this paper proves that NMR enables almost absolute measurement of flow rate. It is interesting to notice that NMR method is the water tracing by water, which cannot be said for tracing water with tritiated water or heavy water. This result is scientifically interesting because, until now, it was considered that tracing water with tritiated or heavy water is tracing by water and that this method makes it dominant over all other methods in which the tracer is subject to other hydrodynamic conditions than water.

ACKNOWLEDGMENT

This work was supported by the research and development project "Termoblok", Electrical Engineering Institute Nikola Tesla, Belgrade, Serbia.

AUTHORS' CONTRIBUTION

S. D. Djekić and S. B. Djekić proposed the idea for the experiment which was carried out by D. P. Nikezić and U. R. Ramadani. All the authors analyzed the results and participated in preparation of the final version of the manuscript under supervision and guidelines of N. M. Kartalović.

REFERENCES

- [1] Dogaru, T., *et al.*, Giant Magnetoresistance-Based Eddy-Current Sensor, *IEEE Trans. Magn.*, 37 (2001), 5, pp. 3831-3838
- [2] Tsymbal, E., Giant Magnetoresistance in Magnetic Metallic Multilayers, *Proceedings*, 3rd Joint Magnetism Workshop, York, UK, 1999
- [3] Ilić, G., *et al.*, Applied Magnetism – Magnetic Devices and Measuring Methods, Monograph, Physics Institute of Technical Faculties, University of Belgrade, Belgrade, 2012
- [4] Barone, A., Principles and Applications of Superconducting Quantum Interference Devices, World Scientific, Singapore, 1998
- [5] Gruenberg, P., Nobel Lecture: From Spinwaves to Giant Magnetoresistance and Beyond, *Rev. Mod. Phys.*, 80 (2008), 4, pp. 1531-1540
- [6] Wikswo, J. P., SQUID Magnetometers for Biomagnetism and Nondestructive Testing: Important Questions and Initial Answers, *IEEE Trans. Appl. Superconductivity*, 5 (1995), 2, pp. 74-120
- [7] Osmokrović, V. P., *et al.*, Radioactive Resistance of Elements for Over-Voltage Protection of Low-Voltage Systems, *Nuclear Instruments and Methods in Physics Research, Section B: Beam Interactions with Materials and Atoms*, 140 (1998), 1-2, pp. 143-151
- [8] Nicholson, P., Non-Destructive Surface Inspection System for Steel and Other Ferromagnetic Materials Using Magneto-Resistive Sensors, *J. Magn. Magn. Mat.*, 160 (1996), pp. 162-164
- [9] Robertson, P. A., Miniature Fluxgate Magnetic Field Sensors, *Proceeding*, Sensor & Transducer Conference, MTEC, Birmingham, UK, 1999
- [10] Osmokrović, V. P., *et al.*, Triggered Vacuum and Gas Spark Gaps, *IEEE Transactions on Power Delivery*, 11 (1996), 2, pp. 858-864
- [11] Osmokrović, V. P., *et al.*, Numerical and Experimental Design of Three-Electrode Spark Gap for Synthetic Test Circuits, *IEEE Transactions on Power Delivery*, 9 (1994), 3, pp. 1444-1450
- [12] Ripka, P., Review of Fluxgate Sensors, *Sensors and Actuators A*, 33 (1996), pp. 129-141
- [13] Osmokrović, V. P., *et al.*, The Influence of the Electric Field Shape on the Gas Breakdown Under Low Pressure and Small Inter-Electrode Gap Conditions, *IEEE Transactions on Plasma Science*, 33 (2005), 5 I, pp. 1677-1681
- [14] Pejović, M. M., *et al.*, Successive Gamma-Ray Irradiation and Corresponding Post-Irradiation Annealing of pMOS Dosimeters, *Nucl Technol Radiat*, 27 (2012), 4, pp. 341-345
- [15] Febvre, P., Digital SQUID Magnetometer Development for Geophysics Applications Validated in Low-Noise Environment, *Proceedings*, IEEE/CSC & Esas European Superconductivity News Forum, 5, 2008
- [16] Rajović, Z., *et al.*, Influence of SF₆-N₂ Gas Mixture Parameters on the Effective Breakdown Temperature of the Free Electron Gas, *IEEE Transactions on Plasma Science*, 41 (2013), 12, pp. 3659-3665
- [17] Osmokrović, V. P., *et al.*, Mechanism of Electrical Breakdown of Gases for Pressures from 10⁻⁹ to 1 bar and Inter-Electrode Gaps from 0.1 to 0.5 mm, *Plasma Sources Science and Technology*, 16 (2007), 3, pp. 643-655
- [18] ***, Evaluation of Measurement Data – Guide to the Expression of Uncertainty in Measurement, First edition September 2008 © JCGM 100:2008
- [19] Vulević, B., Osmokrović, V. P., Evaluation of Uncertainty in the Measurement of Environmental Electro-

- magnetic Fields, *Radiation Protection Dosimetry*, 141 (2010), 2, pp. 173-177
- [20] Stanković, K., et al., Reliability of Semiconductor and Gas-Filled Diodes for Over-Voltage Protection Exposed to Ionizing Radiation, *Nucl Technol Radiat*, 24 (2009), 2, pp. 132-137
- [21] Stanojević, N. Z., et al., Application of Complex Statistical Distributions and Natural Isotopes of Hydrogen and Oxygen for Assessment of Water Origin in Šar Mountains Aquatorium, *Nucl Technol Radiat*, 35 (2020), 2, pp. 172-180
- [22] Osmokrović, P., et al., Validity of the Space-Time Enlargement Law for Vacuum Breakdown, *Vacuum*, 85 (2010), 2, pp. 221-230
- [23] Stanković, K., et al., Surface-Time Enlargement Law for Gas Breakdown, *IEEE Transactions on Dielectrics and Electrical Insulation*, 15 (2008), 4, pp. 994-1005
- [24] Stanojević, N. Z., et al., Research on Water Interconnections within the Šar Mountains Aquatorium by Radioactive Hydrogen Isotope Tritium, *Nucl Technol Radiat*, 34 (2019), 4, pp. 392-398

Received on June 14, 2021

Accepted on July 8, 2021

**Ненад М. КАРТАЛОВИЋ, Сашка Д. ЂЕКИЋ, Саша Б. ЂЕКИЋ,
Душан П. НИКЕЗИЋ, Узахир Р. РАМАДАНИ**

**МОГУЋНОСТ ПРИМЕНЕ НУКЛЕАРНЕ МАГНЕТНЕ
РЕЗОНАНЦИЈЕ ЗА МЕРЕЊЕ ПРОТОКА ТЕЧНОСТИ**

У раду се разматра примена нуклеарне магнетне резонанције за мерење протока течности. Рад је експерименталног карактера. Протокомери на бази нуклеарне магнетне резонанције су изузетно прецизни. Комбинована мерна несигурност може бити 0.1 %. Таква вредност мерне несигурности указује да се ради о одређивању детерминистичке, а не стохастичке величине. Овако висок степен поузданости методе је теоријски и математички објашњен. У раду је приказана мерна шема за мерење протока. Извршено је мерење протока воде на принципу нуклеарне магнетне резонанције и на бази трициране воде (која се сматра најтачнијом класичном методом). Добијени резултати показују да је мерење протока на бази нуклеарне магнетне резонанције тачније (нарочито при већим протоцима). Ово је објашњено већом инерцијалном масом молекула трициране воде НТО од масе стандардне H_2O и могућим прелазом трициране воде у H^3HeO . На овај начин је доказано да је трасирање воде на основу нуклеарне магнетне резонанције једино право трасирање воде водом. Резултати рада доказују да трасирање воде трицираном или тешком водом није трасирање воде водом што је објашњено различитим инерцијалним масама.

Кључне речи: нуклеарна магнетна резонанција, протокомер, трицијумска вода